



UCISA2008, SECC Glasgow

The booking procedure will be the same as in previous years in that you will only be booking the exhibition space (which includes the shell scheme, carpet and a basic electrical package), with UCISA. Please note that if you book *space only* the electrical package and name boards are **not** included. The stand charge includes all daytime refreshments and dinner on Wednesday for up to 3 exhibitors over the 2 days. More than 3 must register as delegates. The Exhibition fee does not include the Conference Dinner on Thursday or accommodation.

For any extra shell scheme, stand fitting or electrical requirements, please deal direct with our exhibition stand builders, Hirex. For furniture requirements, please deal direct with Europa International. You will find the Europa furniture catalogue at www.europainternational.com. From their home page the site is split into sections for tables, chairs, cupboards etc. Once you find a product you're interested in, click on it for prices, sizes, colour options and a bigger photo.

On receipt of your booking form, a stand will be allocated on a *first come, first served* basis with corporate members and sponsors having priority of location. The Conference runs from lunchtime on Wednesday 12 March until lunchtime on Friday 14 March and the Exhibition is open from 1100 – 1800 on 12 March and 0900 – 1700 on 13 March. The Exhibition will be held in Hall 5 where the Conference delegates will take their tea, coffee and lunch breaks. Please complete the exhibitor/delegate booking form that you will find on the Conference website (www.ucisa.ac.uk/events/2008/conference/) giving details of your exhibitors (for security and catering purposes) by the booking deadline. As previously mentioned, the exhibitor pack includes all daytime refreshments and dinner on Wednesday for up to 3 exhibitors over the 2 days. More than 3 must register as delegates. The Exhibition fee does not include the Conference Dinner on Thursday or accommodation.

As last year, we are offering you the opportunity to become overall sponsors of the event with a choice of 3 different levels – Platinum, Gold and Silver. The cost of Platinum sponsorship is £7.5K+, Gold £5–7,499K and Silver £2,500–4,999K. Full details are listed below.

The booking deadline for stands and/or sponsorship is **Friday 11 January 2008**. On receipt of your booking form, you will be sent an invoice **which must be paid in full before the event**. ***Please note, cancellations will not be accepted after the booking deadline.***

Details of each exhibitor will be included in the Conference handbook. I should be grateful if you could provide me with a brief summary (1-200 words) about your company, preferably when you submit your booking form but, at the latest, by **Friday 1 February**.

We look forward to hearing from you.

A handwritten signature in black ink that reads "Sue Fells". The signature is written in a cursive, flowing style.

Sue Fells



UCISA 2008 Management Conference

EXHIBITION STAND BOOKING FORM

The booking deadline is **Friday 11 January 2008**

Price

a) The **Shell Scheme** package price of £295 member (£395 non-member) per m² + 17.5% VAT includes: the shell scheme; carpet; a basic electrical package (2 x spots and 1 x 8 amp socket); all meals and refreshments (from lunch on 12 until lunch on 13 March for up to 3 people); entrance to the conference sessions. ***It does not include the Conference Dinner on Thursday or accommodation.***

b) The **Space Only** package price of £295.00 member (£395 non-member) per m² + 17.5% VAT includes: carpet; exhibitor refreshments during the day; entrance to the conference sessions. ***It does not include the Conference Dinner on Thursday or accommodation.***

Do you require the a) shell scheme or b) space only package? _____.

NB If booking Space Only, you will need to order your electrical package separately.

Wireless internet access will be available to all stands

Do you have any special requirements? _____

All stands are a standard 3 x 2 metres.

We wish to book an exhibition stand of _____ m². Size _____ m x _____ m.

We wish to sponsor _____ for £ _____.

Please send an invoice against our Purchase Order No _____ or

NB Cancellations will not be accepted after the booking deadline.

Company name _____

Address _____

Town/City _____ Postcode _____

Tel No _____ Fax No _____

Email _____

Contact name _____

Invoice address (if different from above) _____

Town/City _____ Postcode _____

Signed _____ Dated _____

Please fax with your official Purchase Order to Sue Fells on 01865 283426



UCISA Corporate Sponsorship

UCISA values the contributions of its Corporate members and, in turn, Corporate members benefit from exposure to the higher education community through attending the UCISA Annual Management Conference. This year, UCISA is making it even easier for corporate members to demonstrate their support for UCISA and its mission of promoting excellence in the application of information systems.



The UCISA Corporate sponsorship packages are an excellent way to increase visibility with all our higher education members, who represent the majority of decision makers and budget holders within the community.

Whilst UCISA has always sought ways to acknowledge your generosity, the Corporate sponsorship package makes your organisation far more visible to those members.

We are offering the following levels of sponsorship:

- Primary sponsorship £10,000
- Platinum sponsorship of £7,500 – £9,999
- Gold sponsorship of £5,000 – £7,499
- Silver sponsorship of £2,500 – £4,999

Sponsorship benefits

 PLATINUM PARTNER	 GOLD PARTNER	 SILVER PARTNER
<ul style="list-style-type: none">• Highest priority for space assignment at the Conference	<ul style="list-style-type: none">• Very high priority for space assignment at the Conference	<ul style="list-style-type: none">• High priority for space assignment at the Conference
<ul style="list-style-type: none">• Opportunity to promote your <i>Business Showcase</i> session in the handbook	<ul style="list-style-type: none">• Opportunity to put your name against a sponsorship opportunity	<ul style="list-style-type: none">• Recognition in the handbook
<ul style="list-style-type: none">• Opportunity to put your name against one of the favoured sponsorship opportunities	<ul style="list-style-type: none">• Recognition in the handbook	<ul style="list-style-type: none">• Two free exhibitor passes to the Conference
<ul style="list-style-type: none">• A full-page mono ad in the handbook	<ul style="list-style-type: none">• Three free exhibitor passes to the Conference	<ul style="list-style-type: none">• A listing on the UCISA website sponsors page
<ul style="list-style-type: none">• Recognition in the handbook	<ul style="list-style-type: none">• A half-page mono ad in the handbook	<ul style="list-style-type: none">• Use of the UCISA silver partner logo in ads and communications
<ul style="list-style-type: none">• Four free exhibitor passes to the Conference	<ul style="list-style-type: none">• A listing on the UCISA website sponsors page	

- A listing on the UCISA website sponsors page
- Use of the [UCISA gold partner logo](#) in ads and communications
- Use of the [UCISA platinum partner logo](#) in ads and communications

Specific items which you may put your name against are:

Conference packs	Gold	£6,500.00
Pads and pens		£2,000.00
Lunch (Wednesday)		£1,500.00
Coaches to Kelvingrove		£1,000.00
Pre dinner reception (Wednesday)		£2,000.00
Dinner wine (Wednesday)	Silver	£2,500.00
Dinner (Wednesday)	Silver	£2,500.00
Entertainment (Wednesday)	Gold	£5,000.00
Lunch (Thursday)		£1,500.00
Pre Conference dinner reception (Thursday)	Silver	£3,000.00
Entertainment (during dinner)	Silver	£2,500.00
Conference Dinner wine	Gold	£5,000.00
Conference Dinner	Primary	£10,000.00
After dinner speaker	Gold	£6,000.00
Conference handbooks	Silver	£2,500.00
Conference wifi access	Silver	£3,000.00
AV	Silver	£3,500.00
Lanyards		£1,500.00

Please note, it is necessary to pay the full value of the item if you wish to be the sole sponsor.

UCISA 2008
12 - 13 MARCH 2008
SECC, GLASGOW

HIREX USE ONLY

	1655 / 755
E.C.	
BOMPAC	
PAYMENT	

Nameboards - Shell Scheme Stands only

Deadline date - TUESDAY 12th FEBRUARY 2008

Stand No.

Your Company Name ONLY will be produced in black Helvetica CAPITAL lettering.

Any other styles must be paid for and only if approved by the organiser.

Please print below in CAPITALS the exact wording you require on your Fascia Board (Maximum 30 Characters)

N.B. Abbreviations will be used in all cases ie/Limited - Ltd.

Company Name: _____

Address: _____

Postcode: _____

Telephone: _____

Facsimile: _____

Contact Name: _____

E-mail: _____

Signature: _____

Date: _____

If we do not receive this form completed by the above date then your Nameboard will be produced using the name taken from your stand booking form supplied to us by the organiser.

Nameboards cannot be altered on site.

Please return to:



Specialists
in
Exhibition
Construction

1 Lomax St, Radcliffe,
Manchester M26 1PX
Telephone: 0161 723 6100
Facsimile: 0161 723 4744

For additional information and examples of how your stand could look, visit our website www.hirex.co.uk where you can complete your name board form and order stand extras in our **SHELL SCHEMES** section.

UCISA 2008
12 - 13 MARCH 2008
SECC, GLASGOW

HIREX USE ONLY

	1655 / 755
E.C.	
BOMPAC	
PAYMENT	

Additional Standfitting order form

for Shell Scheme Stands **ONLY**

Deadline date - TUESDAY 12th FEBRUARY 2008

Stand No.

Item	Price	Quantity	Total
Extra panels - 1000mm (Full Height)	£ 44.00		
Extra panels - 500mm (Full Height)	£ 28.00		
Extra panels - 1000mm x 1000mm (Low Panel)	£ 40.50		
Door panels - 1000mm section	£ 92.25		
Window panels - 1000mm section	£153.50		
Shelves - 1000mm x 240mm	£ 19.50		
1m wire display racks (Not into corners of stands)	£ 24.75		
A4 wallmount leaflet dispensers	£ 11.00		
Lighting support beams	£ 6.75 Per m		
Coat hooks fixed to shell	£ 6.75		
Nightsheets (Exhibitor to supply own padlocks)	£ 12.50 Per m		
Colour change to walls (Per 1m x 2.4m face)	£ 58.00		
Garment rail (1m section)	£ 19.50		
Counters 960mm(l) x 610mm(d) x 915mm(h)	£ 37.50		
Changing room (corner 1m x 1m inc coat hook, curtain)	£ 90.00		
Pop up systems & Banner stands for sale www.hirex.co.uk			

Please send sketch showing items ordered i.e. heights & positions of shelves, wire racks, panels & doors etc on the grid of the shell scheme extras form.

15% Surcharge (if applicable)

Sub Total

3% Surcharge for Credit Card payments

Total

Vat

Total

Velcro type fixings will be sold on site

Company Name:

Address:

Postcode:

Telephone:

Facsimile:

Contact Name:

Signature:

E-mail:

Date:

Please return this form to the address below no later than the above deadline date, together with a cheque for the total amount of order including VAT - made payable to: **Hirex Ltd** or complete your credit card details opposite. All credit card payments are subject to a 3% surcharge.

Credit Details: Mastercard Visa Amex

Start date: / / Expiry date: / /

Credit Card No:

Security Code (last 3 digits):

Orders received after the deadline date are subject to availability and a 15% surcharge.

Note: Any item requested on site will be supplied subject to availability but will incur a surcharge of 25% payable immediately.

No goods will be supplied unless full payment is received

Please return to:

Specialists
in
Exhibition
Construction

1 Lomax St, Radcliffe,
Manchester M26 1PX
Telephone: 0161 723 6100
Facsimile: 0161 723 4744

'Click' Shell Scheme Construction Details

The Shell Scheme is built using the 'Click' Modular system consisting of aluminium uprights (which protrude 20mm off the panels) and aluminium cross rails running top and bottom of the panels. Exhibitors with specific queries should contact **Hirex**.

Panels

Panels are covered in fire retardent black material which accepts velcro fixings.

Under no circumstances must anything be nailed, screwed or glued to the shell scheme panels or metal frame work of the stand. All damage will be charged to the exhibitor at full replacement cost.

Graphics can be attached to stands direct with velcro (maximum width between uprights is 945mm). Exhibitors with larger graphics should contact **Hirex** for advice.

Nameboards

Exhibitors booking shell scheme sites should complete and return the nameboard form in the exhibitor manual. Should you fail to complete this form your name will be supplied by the organiser from your stand booking form. Nameboards cannot be altered on site.

Corner Sites

All corner sites will be open to the gangways with fascia to the perimeters overhead. Should you require additional walls please complete the additional standfitting order form and return it with payment to **Hirex** by the required deadline date.

Island Sites

Stands that are open to gangways on all sides. All island sites will have fascia to the perimeters with ceiling supports and vertical uprights within the stand where deemed necessary by **Hirex**. Exhibitors with large stands should check with **Hirex** for construction. Should you require additional walls please complete the additional standfitting order form and return it with payment to **Hirex** by the required deadline date.

Multiple Stands

All multiple stands will have dividing walls removed, however front uprights, fascia and ceiling structure will remain. The height under ceiling cross rails is 2335mm.

Space Only Sites

Space only sites are not permitted to attach anything to the adjoining shell scheme. Exhibitors taking space only sites backing onto, surrounded by or adjoining shell scheme sites should not assume that panels facing their stand will be finished. **Hirex** are not contracted to supply finished panels (ie. covered with material) to these sites. Space only exhibitors booking stands between shell scheme sites must deduct 55mm from overall measurements to fit within the allotted space (eg. a 3m x 2m space only site would in fact have floor dimensions of 2945mm x 1945mm).

Failure to note this will mean that your stand may not fit in the allotted site.

Hirex reserve the right to amend specifications without notice.

The logo for Hirex, featuring the word "Hirex" in a bold, white, sans-serif font. The letter "i" is positioned above the "r". The logo is set against a black background.

Specialists
in
Exhibition
Construction

1 Lomax St, Radcliffe,
Manchester M26 1PX
Telephone: 0161 723 6100
Facsimile: 0161 723 4744

For additional information and examples of how your stand could look, visit our website www.hirex.co.uk where you can complete your name board form and order stand extras in our **SHELL SCHEMES** section.

Example of a typical corner stand

Please read in conjunction with the 'Click' Shell Scheme Construction Details sheet

STAND No.
STAND NAME (on fascia 150mm deep)

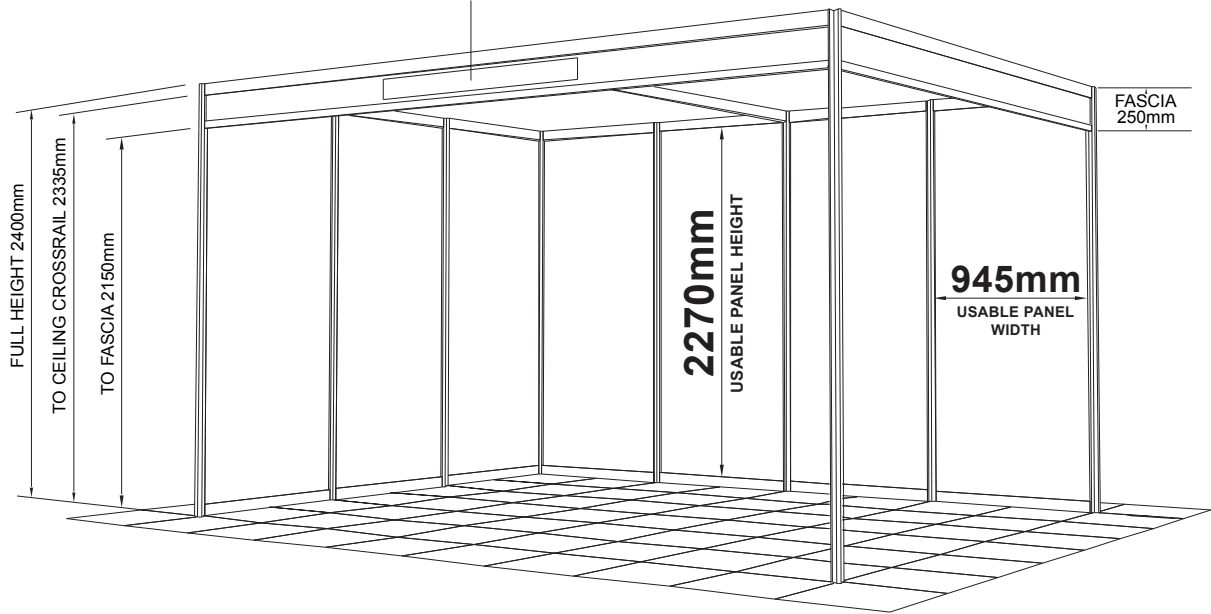

Shell Height 2400mm

Height under ceiling
Cross Rail 2335mm

Walls – Black textured fabric which accepts velcro fixings. No other fixings are permitted. Panels are attached to each other by aluminium uprights which stand 20mm proud. Fixings for large or special graphics are available on request from **Hirex**.

Nameboards – Showing exhibitors name.

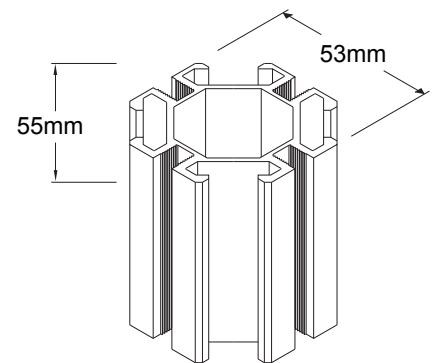
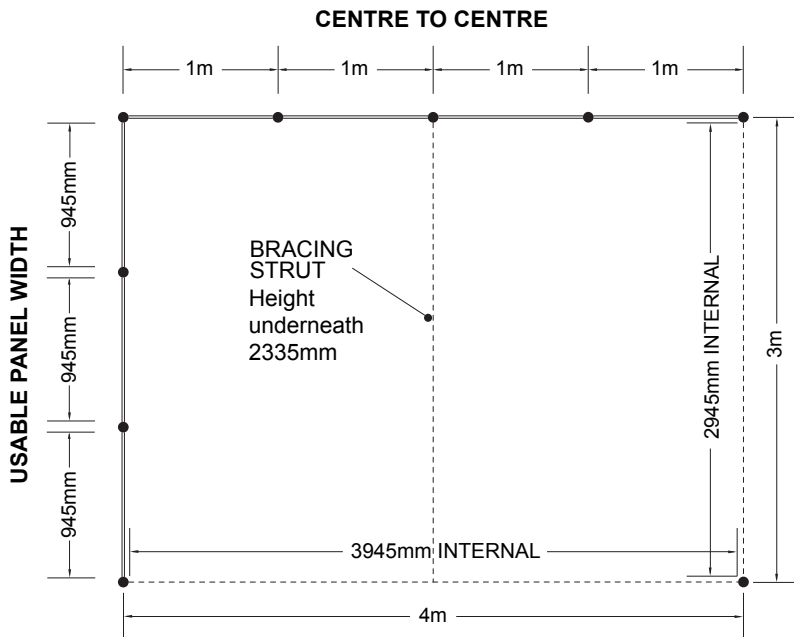

Design and dimensions of individual stands may vary. Exhibitors are advised to check important details directly with **Hirex**. Any fixing or other queries, please contact **Hirex**.



Specialists
in
Exhibition
Construction

1 Lomax St, Radcliffe,
Manchester M26 1PX
Telephone: 0161 723 6100
Facsimile: 0161 723 4744

For additional information and examples of how your stand could look, visit our website www.hirex.co.uk where you can complete your name board form and order stand extras in our **SHELL SCHEMES** section.

Shell Scheme Extras

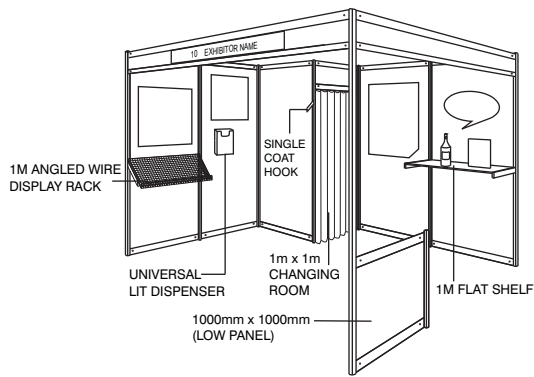

GARMENT RAIL
1000mm

SHELVING
1000mm x 240mm

ANGLED
WIRE DISPLAY
RACK
(DEPTH 350mm)

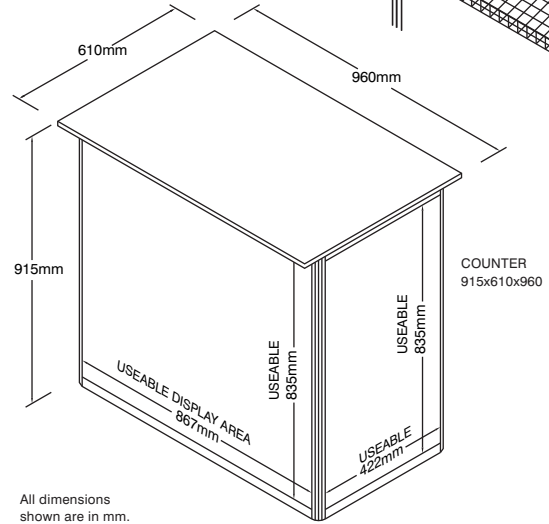
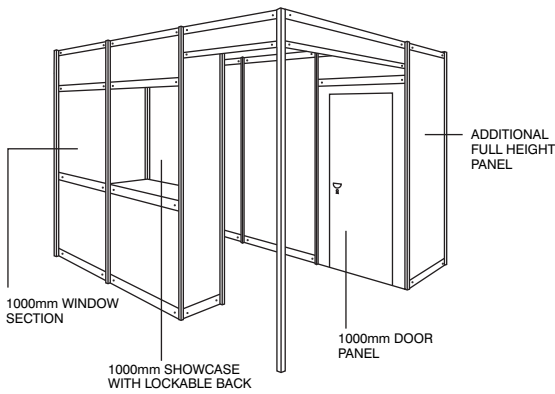

Please indicate position and heights of shelves and wire racks etc. Please note wire racks **CANNOT** be positioned into the corners of stands. If ordering door panels, additional panels for walls etc, please indicate location on plan below.

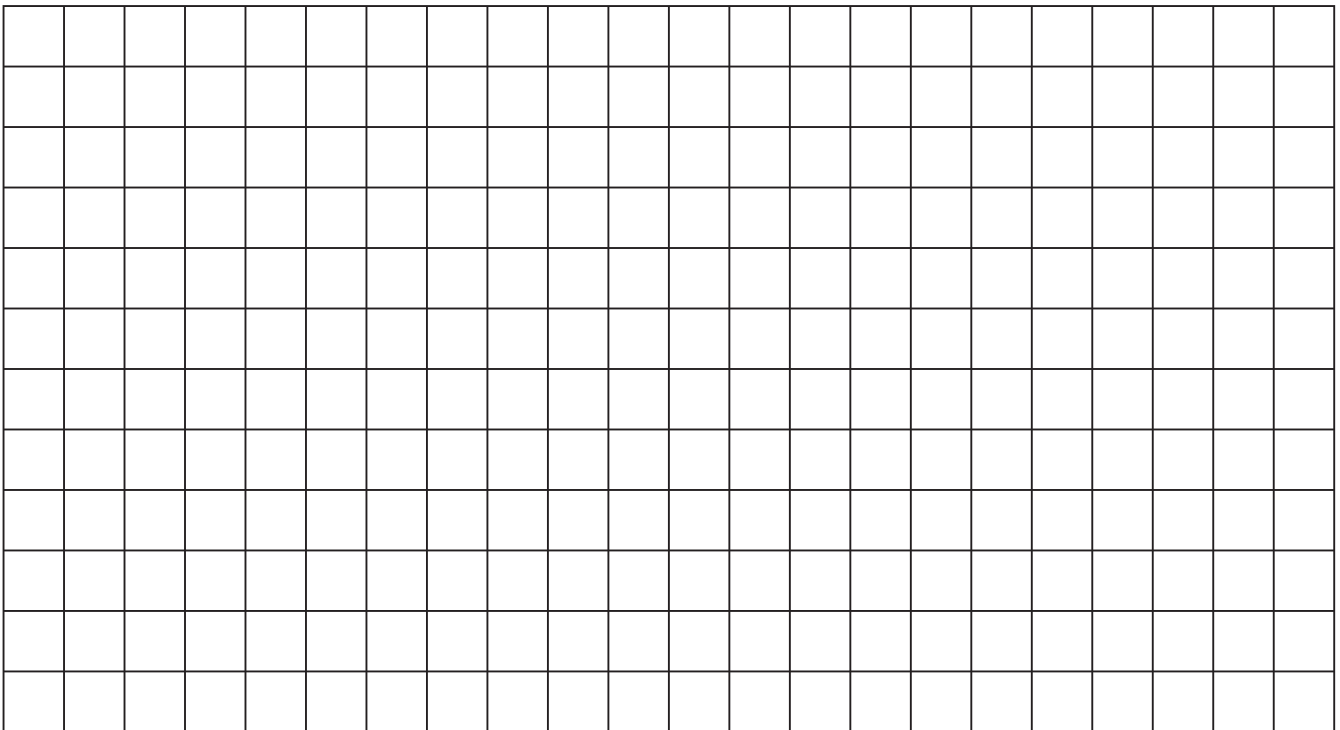

FRONT OF STAND



Specialists
in
Exhibition
Construction

1 Lomax St, Radcliffe,
Manchester M26 1PX
Telephone: 0161 723 6100
Facsimile: 0161 723 4744

For additional information and examples of how your stand could look, visit our website www.hirex.co.uk where you can complete your name board form and order stand extras in our **SHELL SCHEMES** section.

2008 PRICELIST

Item Code	Hire Cost	Item Code	Hire Cost	Item Code	Hire Cost	Item Code	Hire Cost
BS-Barstools		DT-Desks		MS-Accessories		TB-Oblong Tables	
BS03	£ 26.00	DT02	£ 66.00	MS01	£ 76.00	TB01	£ 41.00
BS05	£ 26.00	DT12	£ 57.00	MS02	£ 74.00	TB03	£ 30.00
BS06	£ 38.00	DT15	£ 48.00	MS03	£ 76.00	TB06	£ 34.00
BS08	£ 32.00	DT17	£ 62.00	MS04	£ 25.00	TB07	£ 32.00
BS09	£ 32.00	DT20	£ 66.00	MS05	£ 112.00	TB08	£ 36.00
BS10	£ 34.00	DT21	£ 76.00	MS06	£ 32.00	TB10	£ 34.00
BS14	£ 37.00	DT22	£ 58.00	MS07	£ 25.00	TB11	£ 36.00
BS31	£ 37.00	DT23	£ 71.00	MS08	£ 26.00	TB12	£ 26.00
BS32	£ 37.00	DT26	£ 51.00	MS11	£ 7.00	TB13	£ 32.00
BS33	£ 34.00	ESD-Panels		MS12	£ 13.00	TB14	£ 135.00
BS34	£ 34.00	ESM02	£ 19.00	MS13	£ 32.00	TB15	£ 25.00
BS36	£ 37.00	ESD01	£ 44.00	MS14	£ 19.00	TB16	£ 25.00
BS38	£ 37.00	ESD02	£ 42.00	MS15	£ 32.00	TB17	£ 92.00
BS39	£ 37.00	ESD03	£ 55.00	MS16	£ 41.00	TB18	£ 79.00
BS40	£ 37.00	ESD04	£ 55.00	MS17	£ 70.00	TB25	£ 40.00
BS41	£ 41.00	ESD05	£ 85.00	MS18	£ 60.00	TB28	£ 64.00
BS42	£ 42.00	ESD06	£ 98.00	MS19	£ 44.00	TB35	£ 108.00
BS43	£ 42.00	ESD07	£ 200.00	MS20	£ 28.00	TB36	£ 69.00
BS44	£ 45.00	ESD12	£ 160.00	MS21	£ 3.00	TB38	£ 92.00
		ESD15	£ 120.00	MS22	£ 36.00	TB41	£ 40.00
		ESD17	£ 80.00	MS24	£ 17.00	TB42	£ 69.00
		ESD25	£ 144.00	MS27	£ 10.00		
				MS28	£ 10.00		
CB-Cupboards		HT-High Tables		MS-Accessories		TC-Chairs	
CB08	£ 53.00	HT02	£ 59.00	MS30	£ 78.00	TC01	£ 17.00
CB12	£ 64.00	HT07	£ 76.00	MS31	£ 20.00	TC02	£ 22.00
CB15	£ 152.00	HT13	£ 59.00	MS32	£ 7.00	TC03	£ 27.00
CB18	£ 47.00	HT20	£ 168.00	MS33	£ 178.00	TC04	£ 37.00
CB19	£ 34.00	HT22	£ 178.00	MS34	£ 62.00	TC06	£ 30.00
CB20	£ 39.00	HT23	£ 152.00	MS41	£ 34.00	TC08	£ 31.00
CB24	£ 74.00	HT26	£ 68.00	MS42	£ 57.00	TC09	£ 35.00
CB25	£ 90.00	HT28	£ 59.00	MS43	£ 75.00	TC10	£ 36.00
CB28	£ 40.00	HT29	£ 87.00	MS44	£ 47.00	TC16	£ 12.00
CB29-Silver	£ 48.00	HT33	£ 68.00	MS45	£ 69.00	TC17	£ 27.00
CB30	£ 64.00	HT38	£ 68.00	MS66	£ 189.00	TC18	£ 27.00
CB31	£ 81.00	HT39	£ 75.00	RT-Round Tables		TC19	£ 20.00
CB32	£ 87.00	HT40	£ 58.00	RT03	£ 53.00	TC23	£ 36.00
CB33	£ 87.00	HT43	£ 65.00	RT04	£ 49.00	TC24	£ 27.00
CB34	£ 102.00	HT44	£ 77.00	RT05	£ 45.00	TC26	£ 25.00
CB35	£ 60.00	HT46	£ 64.00	RT06	£ 58.00	TC28	£ 37.00
CB36	£ 84.00	HT47	£ 72.00	RT07	£ 42.00	TC30	£ 57.00
CB38	£ 126.00	HT51	£ 74.00	RT08	£ 42.00	TC31	£ 27.00
CB39	£ 116.00	LC-Lounge seats		RT09	£ 47.00	TC32	£ 25.00
CB40	£ 98.00	LC20	£ 35.00	RT10	£ 52.00	TC34	£ 27.00
CB41	£ 106.00	LC21	£ 35.00	RT11	£ 47.00	TC35	£ 37.00
CB42	£ 116.00	LC22	£ 35.00	RT12	£ 44.00	TC36	£ 37.00
CB43	£ 126.00	LC25	£ 39.00	RT15	£ 50.00	TC37	£ 37.00
		LC26	£ 41.00	RT17	£ 74.00	TC38	£ 37.00
		LC27	£ 36.00	RT18	£ 45.00	TC39	£ 29.00
		LC28	£ 40.00	RT20	£ 42.00	TC40	£ 28.00
		LC29	£ 55.00	RT21	£ 64.00	TC41	£ 25.00
		LC30	£ 35.00	RT23	£ 62.00	TC42	£ 30.00
		LC31	£ 35.00	RT25	£ 38.00	TC47	£ 20.00
		LC32	£ 70.00	RT30	£ 38.00	TC51	£ 28.00
		LC34	£ 115.00	RT31	£ 46.00	GF06	£ 12.00
		LC35	£ 174.00	RT32	£ 38.00		
		LC36	£ 234.00	RT34	£ 74.00		
		LC40	£ 48.00	RT35	£ 46.00		
		LC43	£ 70.00	RT36	£ 66.00		
		LC44	£ 37.00	RT41	£ 51.00		
		LC45	£ 99.00	RT42	£ 39.00		
		LC46	£ 37.00	RT43	£ 33.00		
		LC50	£ 85.00	RT45	£ 33.00		
		LC51	£ 65.00	RT46	£ 27.00		
		LC52	£ 105.00	RT47	£ 41.00		
		LC53	£ 74.00	RT48	£ 41.00		
		LC54	£ 146.00	RT49	£ 44.00		
				RT51	£ 57.00		
				GF01	£ 26.00		
				GF02	£ 28.00		
		LS-LOW STOOLS					
		LS01	£ 27.00				
		LS02	£ 27.00				
		LS07	£ 27.00				
		LS36	£ 27.00				
		LS50	£ 75.00				
		DS-Display					
DS01	£ 117.00						
DS03	£ 178.00						
DS04	£ 141.00						
DS06	£ 152.00						
DS07	£ 105.00						
DS08	£ 72.00						
DS17	£ 66.00						
DS19	£ 64.00						
DS19-AS/FS	£ 10.00						
DS21	£ 62.00						
DS22	£ 62.00						
DS23	£ 60.00						
DS24	£ 108.00						
DS25	£ 44.00						
DS26	£ 55.00						
DS27	£ 64.00						
DS29	£ 35.00						
DS30	£ 48.00						
DS32	£ 51.00						
DS33	£ 45.00						
DS37	£ 68.00						
DS44	£ 190.00						
DS45	£ 87.00						
DS46	£ 128.00						
DS50	£ 135.00						
DS51	£ 135.00						
DS52	£ 168.00						

20 August 2007

NB ALL PRICES SUBJECT TO UK VAT RATE RULING AT TIME OF ORDER

PRICES INDICATED ARE FOR A MAXIMUM OF A SEVEN DAY HIRE PERIOD

T. 08454 303015

F. 08454 303016

w. www.europainternational.com
e. sales@europainternational.com

the furniture, carpet & panel hire people



Floorcovering		
Prices per m2-minimum £30.00		
e-cord	£	6.00
>12m2 - 4m wide - On Sale		
e-cord	£	5.00
<12m2 - 4m wide - On Sale		
e-tiles	£	9.00
0.5m x 0.5m-Hire		
e-vinyl	£	10.00
4m wide - On Sale		
i-velvet	£	10.00
4m wide - On Sale		

Conditions of Hire

- 1 **Europa International** herein after **the company** let furnishings on hire only on the following terms and conditions and will not accept or be bound by other conditions so far as they conflict with the following.
- 2 The period of hire commences from the time of delivery to the person destination or site indicated on the order form from the hirer or where ordered on the telephone by the person placing the order. This shall continue until the furnishings (comprising of furniture, carpet and modular) are accepted back by the company. RISK OF LOSS OR DAMAGE will be on the part of the hirer throughout the period of the hire until collected or delivered back to our premises.
- 3 The hirer shall rent the furnishings at the rates quoted by the company or any subsequently increased rate in force at the commencement of the hire period. The company reserves the right at any time without notice to increase charges (particularly where there is a change in the value of the pound sterling). The hirer undertakes to fully insure all furnishings for the hire period plus at least 3 days prior and 1 day after the conclusion of the event for a sum of not less than five times the hire price.
- 4 The hirer shall provide at the specified destination a duly authorised representative to accept the furnishings and to give a written receipt. If the hirer fails to provide for this the company shall issue a delivery note to the hirer as conclusive proof of time and delivery by the company.
- 5 The company rents furnishings in good order and condition. The receipt signed by the representative of the hirer or in the absence of such a receipt the company's delivery note shall be conclusive evidence of such good order and condition unless at the time of delivery or within 24 hours the hirer shall notify any defect to the company by telephone or fax whereupon all responsible efforts will be made to rectify the problem. The hirer undertakes to take care to avoid damage or theft of hired items and to take all reasonable steps to keep and return the furnishings to the company in first class condition. If items of furniture are broken, damaged or lost then the hirer is liable to repair or replacement costs as agreed between the company and the hirer. NOTE: - We reserve the right to upgrade or change any item that is out of stock.
- 6 The company will endeavour to effect delivery of hired furnishings at the time indicated by the hirer but will not under any circumstances be liable for any delay in delivery caused by circumstances beyond the company's control. Liability for any delay in any case will be limited to the refund of any hire charges already paid by the hirer relating to periods of non-delivery or late delivery.
- 7 Instructions of the hirer (different from those on the requisition) cannot be carried out unless given in writing to the company 7 days prior to action required and accepted by the company in writing. At the discretion of the company a charge of not less than 25% may be made on all orders cancelled prior to delivery. For on-site cancellations where delivered correctly NO refund will be issued.
- 8 If the hirer fails to make available for collection the furnishings at the end of the hire period the hirer shall be liable to pay loss of hire charge at a pro-rata rate until such time as the furnishings are returned to the company or notifies the company by recorded delivery of the loss of furnishings.
- 9 The hirer will be expected to empty all lockable items of their property at the close of show. The company can not be held responsible for goods left in said items and removed to effect collection.
- 10 The furnishings shall remain the property of the company and the hirer shall at all times keep the furnishings in their possession and free from any lien charge or other encumbrance whatsoever. The period of hire shall cease forthwith in the event that any winding up procedures (compulsory or voluntary) are commenced in respect of the hirers business or if any receiver trustee or liquidator is appointed of the hirers business or of any substantial part of its assets.
- 11 Carpets and Carpet Tiles - All skirtings to platforms must be removed to allow carpet to be fitted over the edge. Extra cutting due to machines, stand building etc. plus any damage to carpets or tiles: - i.e. oil, ink, ripping etc. we reserve the right to charge. Fitting to design or walls will be charged as extra. All carpets (not tiles) are laid on an outright sale basis unless arranged otherwise.

No liability shall be attached to the company for:
 - a. Skirtings which have to be removed for the purpose of laying carpets.
 - b. Loss or damage however caused to customer's own goods.
 - c. Any dilapidation for fixing to hall floors (we use low tack tape, as specified).All carpets are charged by using full widths of carpet (normally 4 metres wide) in the most economical method.
- 12 Hire period is up to 7 days thereafter a supplementary hire charge on a daily pro-rata basis. Prices include delivery and collection where we are the appointed contractor. In other events there may be a delivery charge, subject to value, we will inform you of this before processing the order.
- 13 Unless otherwise agreed all charges as per invoices shall be paid 21 days prior to delivery.

CONDITIONS OF HIRE

1. **Europa International** herein after **the company** let furnishings on hire only on the following terms and conditions and will not accept or be bound by other conditions so far as they conflict with the following.
2. The period of hire commences from the time of delivery to the person destination or site indicated on the order form from the hirer or where ordered on the telephone by the instructions of the person placing the order. This shall continue until the furnishings (comprising of furniture, carpet and modular) are accepted back by the company. RISK OF LOSS OR DAMAGE will be on the part of the hirer throughout the period of the hire until collected or delivered back to our premises.
3. The hirer shall rent the furnishings at the rates quoted by the company or any subsequently increased rate in force at the commencement of the hire period. The company reserves the right at any time without notice to increase charges (particularly where there is a change in the value of the pound sterling). The hirer undertakes to fully insure all furnishings for the hire period plus at least 3 days prior and 1 day after the conclusion of the event for a sum of not less than five times the hire price.
4. The hirer shall provide at the specified destination a duly authorised representative to accept the furnishings and to give a written receipt. If the hirer fails to provide for this the company shall issue a delivery note to the hirer as conclusive proof of time and delivery by the company.
5. The company rents furnishings in good order and condition. The receipt signed by the representative of the hirer or in the absence of such a receipt the company's delivery note shall be conclusive evidence of such good order and condition unless at the time of delivery or within 24 hours the hirer shall notify any defect to the company by telephone or fax whereupon all responsible efforts will be made to rectify the problem. The hirer undertakes to take care to avoid damage or theft of hired items and to take all reasonable steps to keep and return the furnishings to the company in first class condition. If items of furniture are broken, damaged or lost then the hirer is liable to repair or replacement costs as agreed between Europa International and the hirer. NOTE: - We reserve the right to upgrade or change any item that is out of stock.
6. The company will endeavour to effect delivery of hired furnishings at the time indicated by the hirer but will not under any circumstances be liable for any delay in delivery caused by circumstances beyond the company's control. Liability for any delay in any case will be limited to the refund of any hire charges already paid by the hirer relating to periods of non-delivery or late delivery.
7. Instructions of the hirer (different from those on the requisition) cannot be carried out unless given in writing to the company 7 days prior to action required and accepted by the company in writing. At the discretion of the company a charge of not less than 25% may be made on all orders cancelled prior to delivery. For on-site cancellations where delivered correctly NO refund will be issued.
8. If the hirer fails to make available for collection the furnishings at the end of the hire period the hirer shall be liable to pay loss of hire charge at a pro-rata rate until such time as the furnishings are returned to the company or notifies the company by recorded delivery of the loss of furnishings.
9. The hirer will be expected to empty all lockable items of their property at the close of show. The company can not be held responsible for goods left in said items and removed to effect collection.
10. The furnishings shall remain the property of the company and the hirer shall at all times keep the furnishings in their possession and free from any lien charge or other encumbrance whatsoever. The period of hire shall cease forthwith in the event that any winding up procedures (compulsory or voluntary) are commenced in respect of the hirers business or if any receiver trustee or liquidator is appointed of the hirers business or of any substantial part of its assets.
11. CARPETS & TILES. - All skirting to platforms must be removed to allow carpet to be fitted over the edge. Extra cutting due to machines, stand building etc. plus any damage to carpets or tiles: - i.e. oil, ink, ripping etc. we reserve the right to charge. Fitting to design or walls will be charged as extra. All carpets (not tiles) are laid on an outright sale basis unless arranged otherwise.
No liability shall be attached to Europa International for:
 - (1) Skirting which has to be removed for the purpose of laying carpets.
 - (2) Loss or damage however caused to customer's own goods.
 - (3) Any dilapidation for fixing to hall floors (we use low tack tape, as specified).All carpets are charged by using full widths of carpet (normally 4 metres wide) in the most economical method.
12. Hire period is up to 7 days thereafter a supplementary hire charge on a daily pro-rata basis. Prices include delivery and collection where we are the appointed contractor. In other events there may be a delivery charge, subject to value, we will inform you of this before processing the order.
13. Unless otherwise agreed all charges as per invoices shall be paid 21 days prior to delivery.

MERIDIAN SERVICES LTD. :

International Exhibition Contractors

94 ASH ROAD, ALDERSHOT, HANTS. GU12 4EY UK

UCI SA - SECC - GLASGOW
12-14 March 2008

Tel: +44 [0] 1252 318893

Fax: +44 [0] 1252 336969

Mobile: 07768-582653

Email info@meridianservices.co.uk

Web site www.meridianservices.co.uk

you may order online if you wish

Full Members Of B.E.C.A [The British Contractors Association]

Equipment Hire	Pro-Forma Invoice		Price in Sterling	Quantity	cost
SPACE ONLY & ISLAND SITES STANDS PLEASE CONTACT THE OFFICE		EURO	£	*INDICATE*	*INDICATE*
Power [square pin] 13 amp socket					
[ONLY 1 PLUG PER SOCKET	Rated at 4 amps	137.60	£86.00		
REF HEALTH & SAFETY REGS]	Rated at 8 amps	208.00	£130.00		
no adaptors are allowed	Rated at 13 amps	238.40	£149.00		
Heavy Power		POA	POA		
Spotlighting					
	Standard Spot Fitted Behind Fascia	48.00	£30.00		
	2 Standard Spots Fitted Behind Fascia	70.40	£44.00		
	Long Arm Spot for Graphics-Pictures	59.20	£37.00		
Track lighting Including Lights <small>Fitted behind fascia</small>					
	4 Foot Length With 4 spots	176.00	£110.00		
	8 Foot Length With 6 spots	208.00	£130.00		
	As Above But 8 Low Voltage Track Spots	224.00	£140.00		
Fluorescent Lighting					
	5 Foot Fitting	51.20	£32.00		
Connecting Exhibitors Own Fitting		POA	POA		
Cooling Fans: Fitted Behind Fascia		25.60	£16.00		
SPECIALISED EQUIPMENT : [LIMITED AVAILABILITY]					
MATCHED PAIR LG 26" WIDE ANGLE LCD FLAT SCREEN COMP. MOINITORS		£165.00	each		
MATCHED PAIR LG 26" WIDE ANGLE LCD FLAT SCREEN DVD UNITS		£180.00	each		
MATCHED PAIR LG 25" CRT SCREEN WITH DVD PLAYER		£145.00	each		
STAND FOR THE ABOVE		£36.00	each		
19" Colour LCD Computer Monitor for Lap Tops		£120.00	each		

ADDITIONAL MAINS CHARGE FROM VENUE FOR SPACE ONLY ISLAND SITE PLEASE CONTACT THE OFFICE

FOR LIGHTING NOT LISTED PLEASE CONTACT THE OFFICE

VAT NO: 492-9672-90

Sub-Total

15% Late Surcharge Fee

Sub-Total

Please Add 17.5% VAT

Total

Stand Number

stand layout
please indicate
positions

FRONT

PRICES INCLUDE MAINS CHARGES FROM VENUE

You may pay by the following credit card (AMEX/ACCESS/MASTERCARD/SWITCH/VISA)

FOR PAYMENT DETAILS PLEASE SEE REVERSE SIDE OF THIS FORM

Name Of Company	
Address:	
Name Of Person Signing	
Signature	
Telephone No:	Fax No:
Please Complete Rear Of Form	

FULL PAYMENT TO REACH OFFICE PRIOR TO EVENT OTHERWISE WE CANNOT GUARANTEE TO SUPPLY REQUIREMENTS

Please Complete The Form And Return With Your Remittance**At Least 14 Days Prior - Otherwise Late Order Surcharge Fee Will Be Applied**

**PLEASE NOTE THAT IF YOU HAVE NOT ALREADY MADE ARRANGEMENTS WITH OUR OFFICE - WE
 RESPECTFULLY ASK FOR FULL PAYMENT OF THIS INVOICE PRIOR TO WORK COMMENCING,**

OTHERWISE WE CANNOT GUARANTEE SUPPLY ON OPENING OF SHOW.

Methods of Payment Cheques to be made payable to MERIDIAN SERVICES LTD.

UK Sterling

EUROS only

Paying in Sterling
By Cheque direct to the office

Direct debit
BACS or CHAPS

To: Bank of Scotland
600 Gorgie Road, Edinburgh EH113XP
Sort Code: 12-20-26
Account No: 06092631
Account Name: Meridian Services Ltd.
Swift Code: BOFSGB21282
Ref: IBAN **GB19 BOFS 1220 2606 0926 31**

Paying by EURO
By EURO Cheque direct to office

Direct Debit
BACS or CHAPS

To: Bank of Scotland
600 Gorgie Road, Edinburgh EH113XP
Sort Code: 12-20-10
EURO Account No: 21736001
Account Name: Meridian Services Ltd.
Swift Code: BOFSGB21EUL
Ref: IBAN **GB81 BOFS 1220 1021 7360 01**



Payment can also be made by Credit Card, please contact the office for a Credit Card form or simply complete the following. Once payment has been collected we will forward you a Credit Card Receipt.

PLEASE NOTE ALL CREDIT CARD TRANSACTIONS WILL BE SUBJECTED TO A 2% SURCHARGE

Card No:		
Name as on Card:		LAST 3 NUMBERS REVERSE OF CARD
Expiry Date:		
Address as on Statement:		
		Post Code:
Phone No:	Fax No:	

Net Amount £:	VAT £:	Total Due £:
----------------------	---------------	---------------------

Invoice No:
Authorisation:
Office use only:

Authorisation:
Office use only: